

FSP 1144

FIRE-RESISTANCE TEST
ON A FIRE COLLAR CAST INTO
A REINFORCED CONCRETE SLAB

In confidence to
TRUSS HOLDINGS PTY LTD

15 AUGUST 2005

FSP 1144

**FIRE-RESISTANCE TEST
ON A FIRE COLLAR CAST INTO
A REINFORCED CONCRETE SLAB**

In confidence to
TRUSS HOLDINGS PTY LTD

15 AUGUST 2005



"Copyright CSIRO 2005 ©"

Copying or alteration of this report without written authorisation from CSIRO is forbidden.

CSIRO – Manufacturing and Infrastructure Technology
14 Julius Avenue, Riverside Corporate Park, North Ryde NSW 2113
Ph: 02 9490 5444 Fax: 02 9490 5528

This Report is subject to binding obligations under which it was prepared. In particular, the Report must not be used:

- as a means of endorsement; or
- in a company prospectus or notification to a Stock Exchange document for capital raising, without the prior written consent of CSIRO.

The Report may be published verbatim and in full, provided that a statement is included on the publication that it is a copy of the Report issued by CSIRO.

Excerpts of the report may not be published.



MANUFACTURING & INFRASTRUCTURE TECHNOLOGY

"Copyright CSIRO 2005 ©" Copying or alteration of this report without written authorisation from CSIRO is forbidden.



This laboratory is accredited (Accreditation No. 3632) by the National Association of Testing Authorities, Australia. The tests reported herein have been performed in accordance with its terms of accreditation.

**FIRE-RESISTANCE TEST
ON A FIRE COLLAR CAST INTO
A REINFORCED CONCRETE SLAB**

SPONSORED INVESTIGATION No. FSP 1144

**IDENTIFICATION
OF SPECIMEN:**

The sponsor identified the specimen as a FireShield Series 3 collar cast into a reinforced concrete slab, protecting a pipe penetration.

SPONSOR:

Truss Holdings Pty Ltd
161 Railway Parade
THORNSIDE QLD

MANUFACTURER:

Fire Protection Solutions Pty Ltd
161 Railway Parade
THORNSIDE QLD

TEST STANDARDS: Australian Standard 1530, Methods for fire tests on building materials, components and structures,
Part 4: Fire-resistance tests of elements of building construction -1997;

Australian Standard 4072, Components for the protection of openings in fire-resistant separating elements,
Part 1: Service penetrations and control joints -1992.

DOCUMENTATION

TEST NUMBER:

FS 3738/2784

TESTED:

The fire-resistance test was conducted on 23 March 2005.

**DESCRIPTION
OF SPECIMEN:**

GENERAL

The specimen comprised a 1150-mm x 1150-mm x 150-mm thick reinforced concrete slab penetrated by one large diameter uPVC pipe, protected by a cast-in FireShield collar. The cast-in collar was cast into the existing reinforced concrete slab using a fast curing cement that was backfilled into a pre-cored hole.



MANUFACTURING & INFRASTRUCTURE TECHNOLOGY

"Copyright CSIRO 2005 ©" Copying or alteration of this report without written authorisation from CSIRO is forbidden.



This laboratory is accredited (Accreditation No. 3632) by the National Association of Testing Authorities, Australia. The tests reported herein have been performed in accordance with its terms of accreditation.

**Penetration – 315-mm Series 3 Cast-in FireShield Collar
FS3S - 315A1 (315-mm uPVC pipe)**

The Series 3 Cast-in FireShield Collar consisted of a 1.2-mm thick steel case, 355-mm in diameter and 190-mm in height.

The collar incorporated 6 springs, these were pivoted at the top of the spring cavity and restrained by a nylon fusible link with a melting temperature of 75 degrees Celsius.

A soft intumescent wrap lined the internal circumference of the collar. The wrap was 10-mm thick x 180-mm wide, and weighed approximately 2860 grams. The wrap was covered on the outside with a stainless steel mesh 0.35-mm thick and 180-mm wide, and on the inside with a 0.35-mm thick x 57-mm wide Colan Type E fibreglass sleeve, extending down from the top of the collar 150-mm.

A nominal 315-mm OD uPVC Vinidex stormwater pipe was fitted through the collar's sleeve. The pipe projected vertically 2000-mm above the slab and approximately 150-mm into the furnace chamber. The pipe above the slab was supported at 1000-mm intervals. The pipe was open at the top and capped at the exposed end.

A concrete hob, approximately 100-mm high, was cast around the portion of the collar projecting above the slab, in order to maintain a minimum 50-mm concrete cover around all of the projecting steel case of the collar.

DIMENSIONS

The specimen's overall dimension was 1150-mm x 1150-mm to suit the opening in the specimen frame.

ORIENTATION

The reinforced concrete slab was placed horizontally on top of the furnace chamber.

DOCUMENTATION: The following documents were supplied by the sponsor as a complete description of the specimen and should be read in conjunction with this report:

Specification, dated 31 May 2005, by Fireball International Pty Ltd

Drawings file Nos. FSTD73 and FSTD73A, both undated by Fireball Collars Pty Ltd.

Confidential information about the test specimen has been submitted and is retained at the Division of Manufacturing and Infrastructure Technology.

EQUIPMENT:**FURNACE**

The furnace had a nominal opening of 1000-mm x 1000-mm for attachment of vertical or horizontal specimens.

The furnace was lined with refractory bricks and materials with the thermal properties as specified in AS 1530.4-1997 and was heated by combustion of a mixture of natural gas and air.



CSIRO

MANUFACTURING & INFRASTRUCTURE TECHNOLOGY

"Copyright CSIRO 2005 ©" Copying or alteration of this report without written authorisation from CSIRO is forbidden.



NATA

This laboratory is accredited (Accreditation No. 3632) by the National Association of Testing Authorities, Australia. The tests reported herein have been performed in accordance with its terms of accreditation.

TEMPERATURE

The temperature in the furnace chamber was measured by four type K, 3-mm diameter, 310 stainless steel Mineral Insulated Metal Sheathed (MIMS) thermocouples. Each thermocouple was housed in high-nickel steel tubes opened at the exposed end.

The temperature in the furnace chamber was also measured by two plate thermometer assemblies as specified in ISO 834.1 – 1999.

The temperatures of the specimen were measured by glass-fibre insulated and sheathed K-type thermocouples with a wire diameter of 0.5-mm.

MEASUREMENT SYSTEM

The primary measurement system comprised a multiple-channel datalogger scanning at one-minute intervals during the test.

AMBIENT

TEMPERATURE: The temperature of the furnace chamber was 22°C at the commencement of the test.

DEPARTURE FROM

TEST STANDARDS: There were no departures from the requirements of AS 1530.4-1997 and AS 4072.1-1992.

**TERMINATION
OF TEST:**

The test was terminated at 185 minutes by agreement with the sponsor.

TEST RESULTS:**CRITICAL OBSERVATIONS**

The following observations were made during the fire-resistance test:

- 1 minute - Smoke is fluing from the top of the pipe.
- 2 minutes - Smoke has ceased fluing from the pipe.
- 3 minutes - Smoke has started to flue from the pipe again.
- 6 minutes - Smoke quantity fluing from the pipe has decreased.
- 11 minutes - Smoke has ceased fluing from the pipe.
- 25 minutes - Small amount of smoke has started to flue from the pipe.
- 60 minutes - No apparent change to the specimen.
- 120 minutes - No apparent change to the specimen.
- 174 minutes - Smoke quantity fluing from the pipe has increased.
- 181 minutes - Test terminated.

**MANUFACTURING & INFRASTRUCTURE TECHNOLOGY**

"Copyright CSIRO 2005 ©" Copying or alteration of this report without written authorisation from CSIRO is forbidden.



This laboratory is accredited (Accreditation No. 3632) by the National Association of Testing Authorities, Australia. The tests reported herein have been performed in accordance with its terms of accreditation.

FURNACE TEMPERATURE

Figure 1 shows the standard curves of temperature versus time for heating the furnace chamber and the actual curves of average and maximum temperature versus time recorded during the heating period.

SPECIMEN TEMPERATURE

Figure 2 shows the curve of maximum temperature versus time associated with the penetration.

PERFORMANCE

Performance observed in respect of the following heating conditions and general AS 1530.4-1997 criteria:

Penetration A – 315-mm Series 3 Cast-in FireShield Collar
FS3S - 315A1 (315-mm uPVC pipe)

Structural adequacy	-	not applicable
Integrity	-	no failure at 185 minutes
Insulation	-	no failure at 185 minutes

For the purposes of AS 1530.4 –1997, the results only relate to the behaviour of the element of construction under the particular conditions of test; they are not intended to be the sole criteria for assessing the potential fire performance of the element in use, nor do they reflect the actual behaviour in fires.

FIRE-RESISTANCE LEVEL:

For the purpose of building regulations in Australia, the fire-resistance levels (FRL) of the test specimen is -/180/180.

The fire-resistance level is applicable for exposure to fire from the same side as tested.

APPENDICES:**APPENDIX 1**

Photograph 1 – Specimen (exposed side) prior to testing.....	Page 7
Photograph 2 – Specimen (unexposed side) prior to testing.....	Page 7
Photograph 3 – Specimen at 61 minutes into the test.....	Page 8
Photograph 4 – Specimen at 121 minutes into the test.....	Page 8
Photograph 5 – Specimen at 181 minutes into the test.....	Page 9
Photograph 6 – Specimen (exposed side) after the completion of testing .	Page 9



APPENDIX 2

Figure 1. - FURNACE TEMPERATURE..... Page 10

Figure 2. - SPECIMEN TEMPERATURE-
Maximum temperature associated with the penetration..... Page 11

APPENDIX 3

Drawing file No. FSTD73, undated, by Fireball Collars Pty Ltd Page 12

Drawing file No. FSTD73A, undated, by Fireball Collars Pty Ltd..... Page 13

APPENDIX 4

A copy of Certificate of Test No. 1923..... Page 14

TESTED BY:

Chris Wojcik
Testing Officer

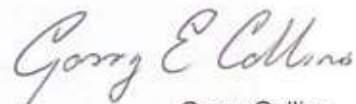
Garry Collins
Manager, Fire Testing and Assessment

15 AUGUST 2005



MANUFACTURING & INFRASTRUCTURE TECHNOLOGY

*Copyright CSIRO 2005 © Copying or alteration of this report without written authorisation from CSIRO is forbidden.



This laboratory is accredited (Accreditation No. 3632) by the National Association of Testing Authorities, Australia. The tests reported herein have been performed in accordance with its terms of accreditation.



Photograph 1 - Specimen (exposed side) prior to testing.

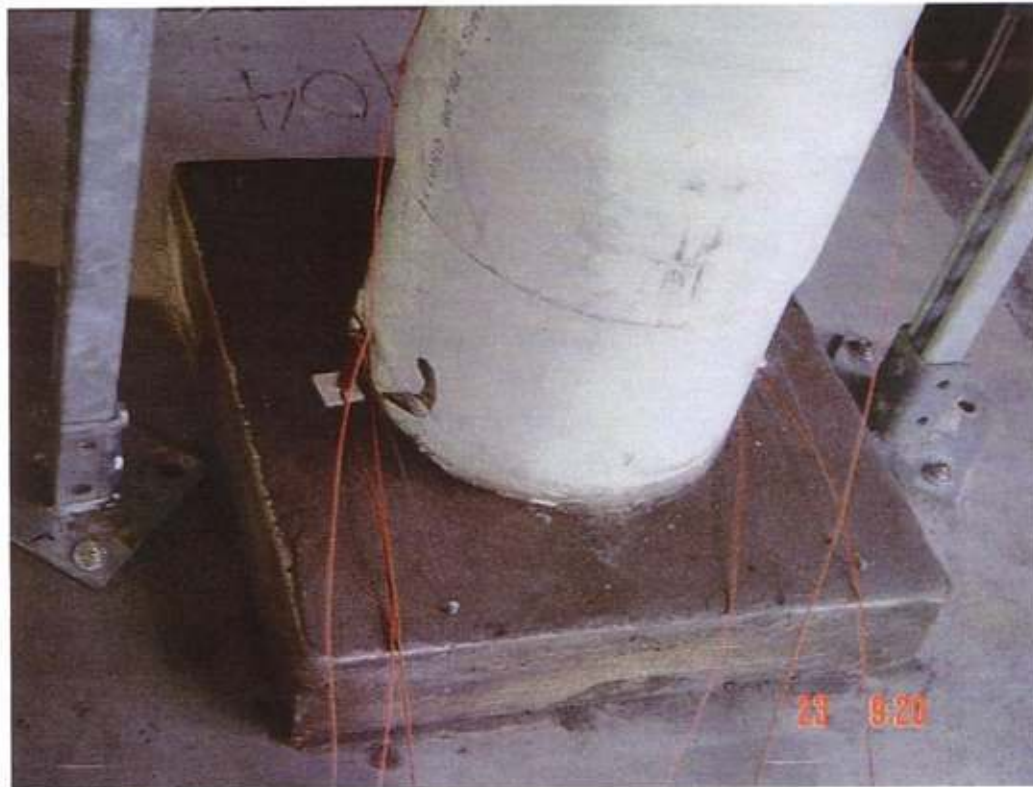

Photograph 2 - Specimen (unexposed side) prior to testing.



CSIRO

MANUFACTURING & INFRASTRUCTURE TECHNOLOGY

"Copyright CSIRO 2005 ©" Copying or alteration of this report without written authorisation from CSIRO is forbidden.



NATA

This laboratory is accredited (Accreditation No. 3632) by the National Association of Testing Authorities, Australia. The tests reported herein have been performed in accordance with its terms of accreditation.



Photograph 3 – Specimen at 61 minutes into the test.



Photograph 4 – Specimen at 121 minutes into the test.



MANUFACTURING & INFRASTRUCTURE TECHNOLOGY

"Copyright CSIRO 2005 ©" Copying or alteration of this report without written authorisation from CSIRO is forbidden.

This laboratory is accredited (Accreditation No. 3632) by the National Association of Testing Authorities, Australia. The tests reported herein have been performed in accordance with its terms of accreditation.



Photograph 5 – Specimen at 181 minutes into the test.

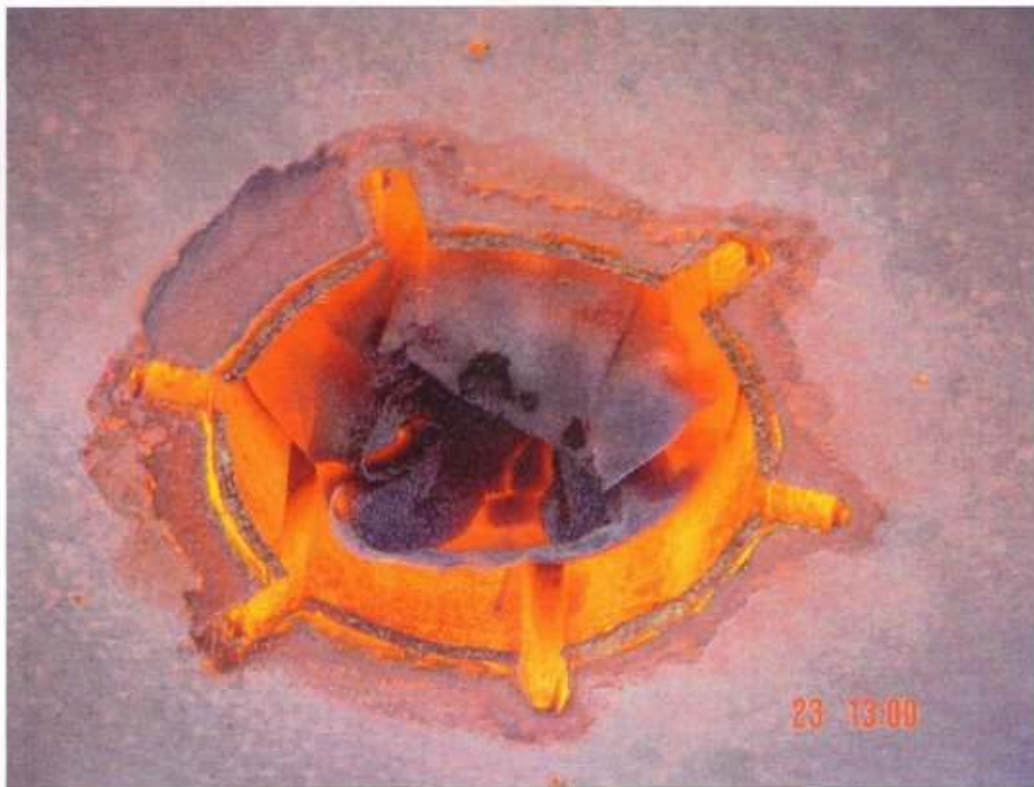

Photograph 6 – Specimen (exposed side) after the completion of testing.



MANUFACTURING & INFRASTRUCTURE TECHNOLOGY

"Copyright CSIRO 2005 ©" Copying or alteration of this report without written authorisation from CSIRO is forbidden.



This laboratory is accredited (Accreditation No. 3632) by the National Association of Testing Authorities, Australia. The tests reported herein have been performed in accordance with its terms of accreditation.

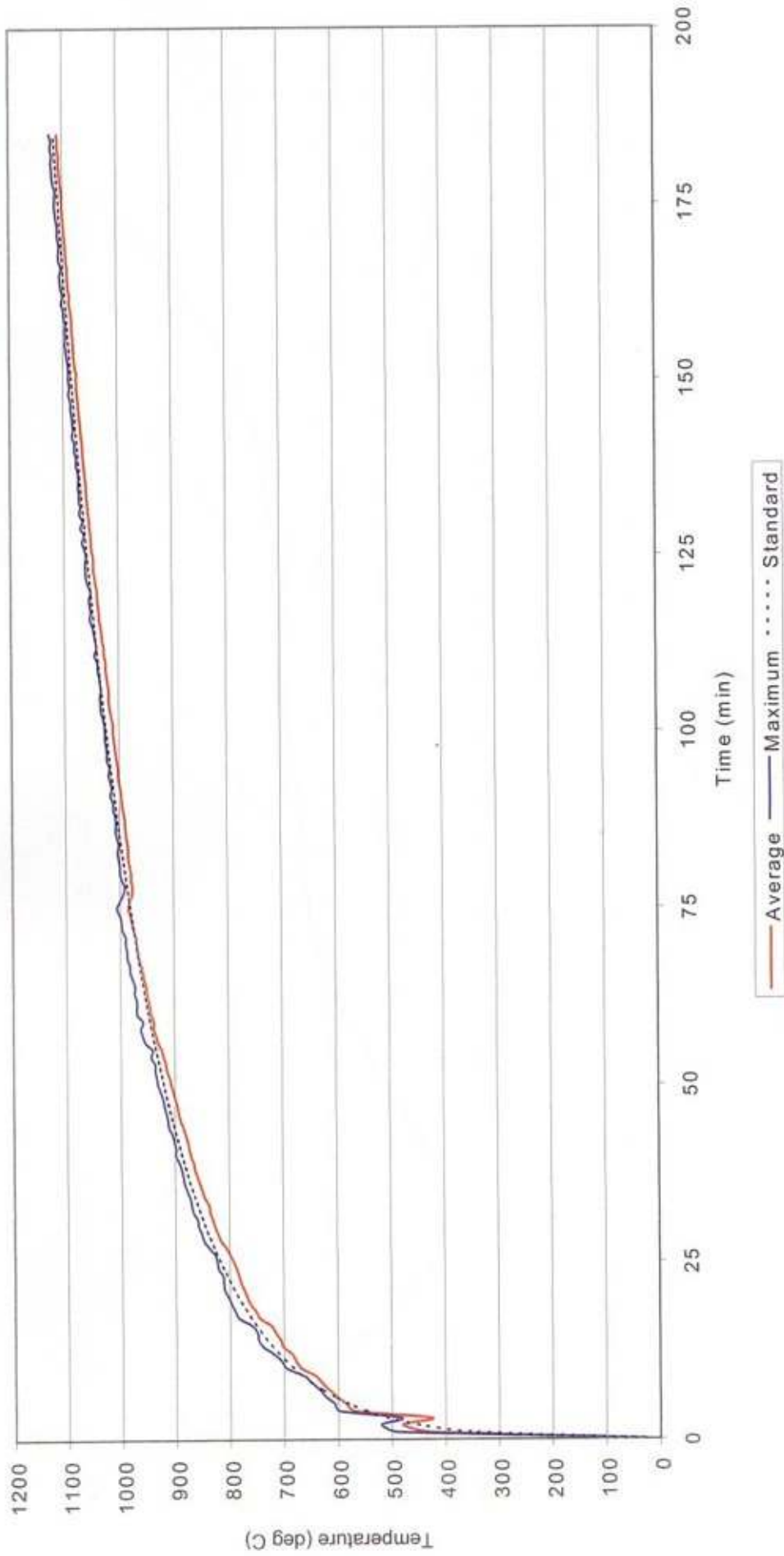

Fig. 1 – FURNACE TEMPERATURE



MANUFACTURING & INFRASTRUCTURE TECHNOLOGY

"Copyright CSIRO 2005 ©" Copying or alteration of this report without written authorisation from CSIRO is forbidden.



This laboratory is accredited (Accreditation No. 3632) by the National Association of Testing Authorities, Australia. The tests reported herein have been performed in accordance with its terms of accreditation.

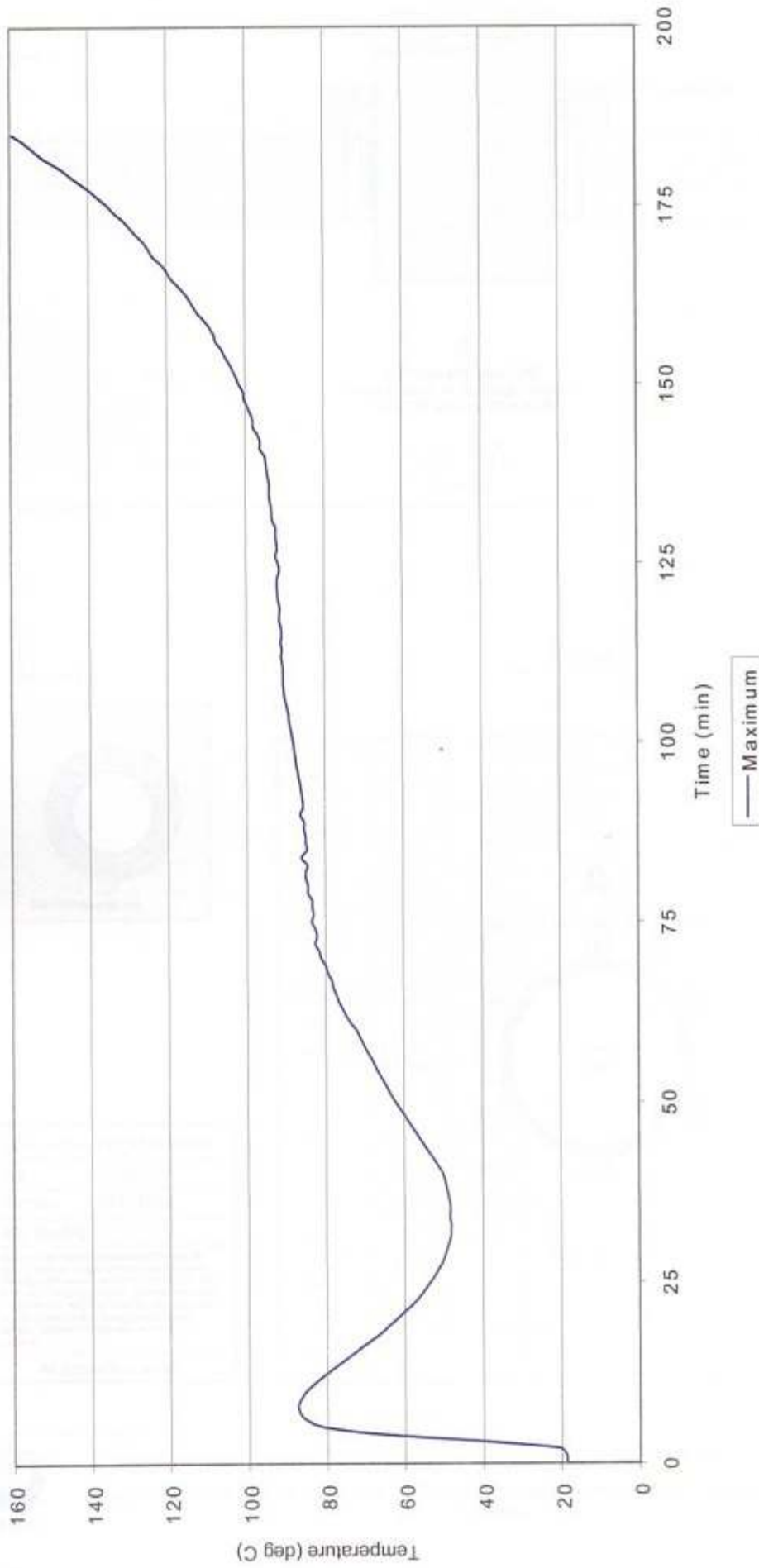

Fig. 2 – SPECIMEN TEMPERATURE
Maximum temperature associated with the pipe penetration



MANUFACTURING & INFRASTRUCTURE TECHNOLOGY

"Copyright CSIRO 2005 ©" Copying or alteration of this report without written authorisation from CSIRO is forbidden.



This laboratory is accredited (Accreditation No. 3632) by the National Association of Testing Authorities, Australia. The tests reported herein have been performed in accordance with its terms of accreditation.

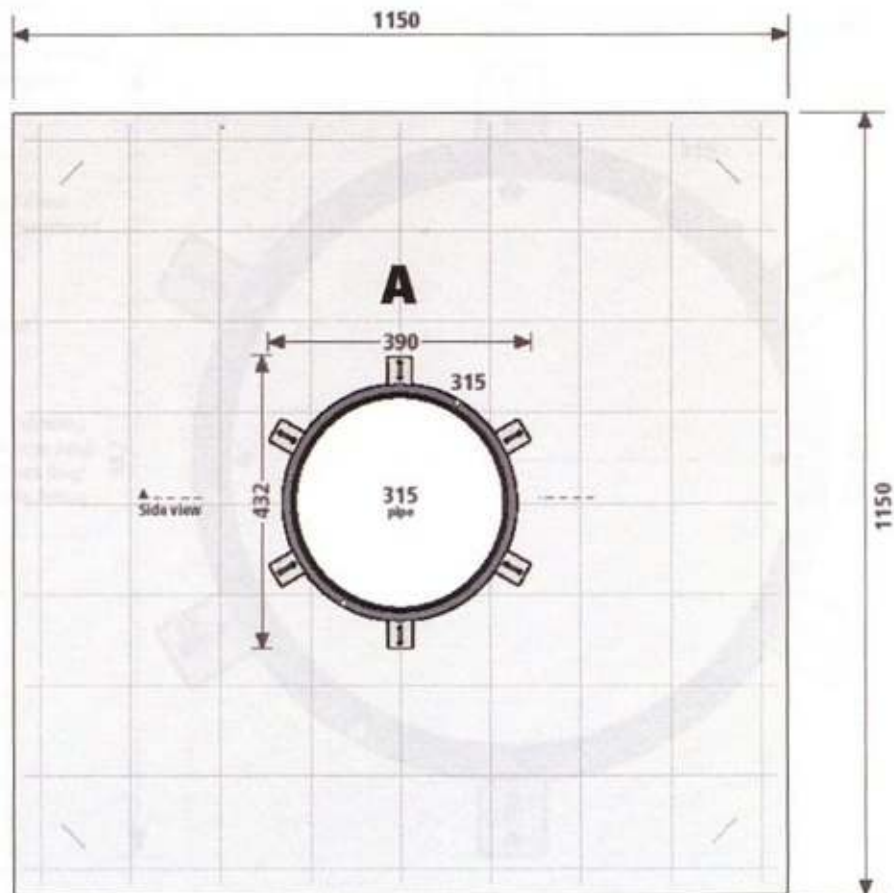
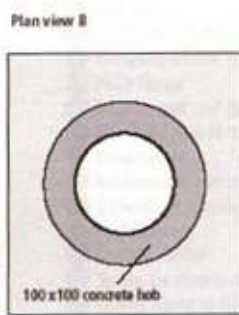
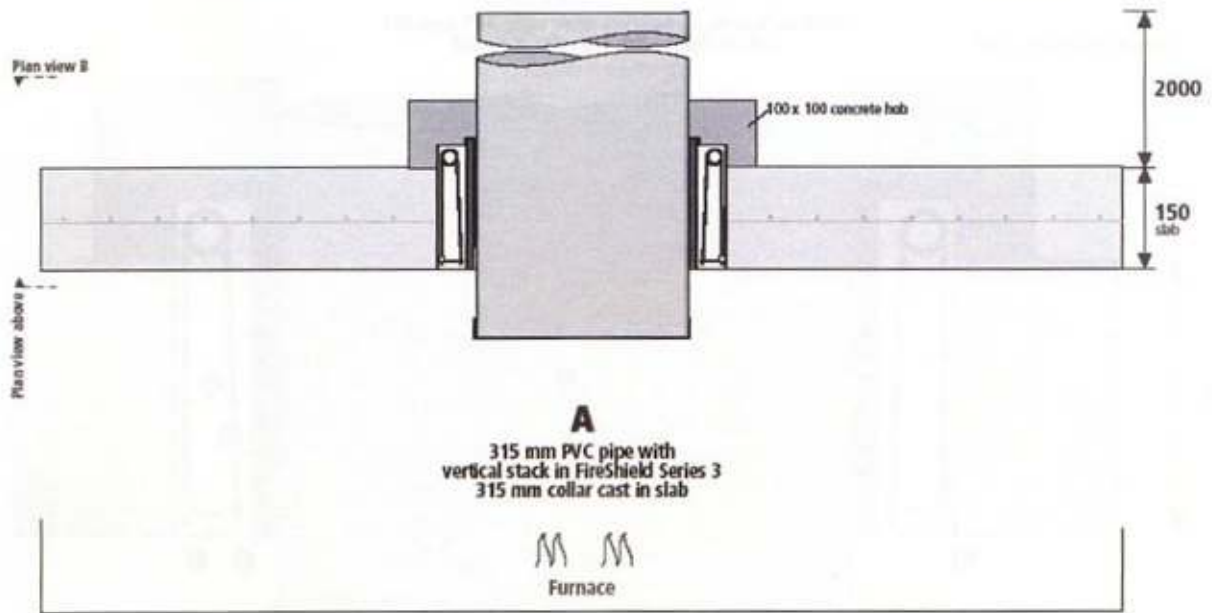

Drawing No.	FSTD73010405
File	FSTD73
Part No.	FS3S315A
Pat.	Pending
<small>Copyright by Fireball International Pty Ltd. All rights reserved. No part of this work covered by the copyright herein may be reproduced or used in any form or by any means - graphic, electronic or mechanical, including photography, recording, taping, or information storage and retrieval systems - without written permission of the publisher.</small>	
All dimensions in mm.	



MANUFACTURING & INFRASTRUCTURE TECHNOLOGY

"Copyright CSIRO 2005 ©" Copying or alteration of this report without written authorisation from CSIRO is forbidden.



This laboratory is accredited (Accreditation No. 3632) by the National Association of Testing Authorities, Australia. The tests reported herein have been performed in accordance with its terms of accreditation.

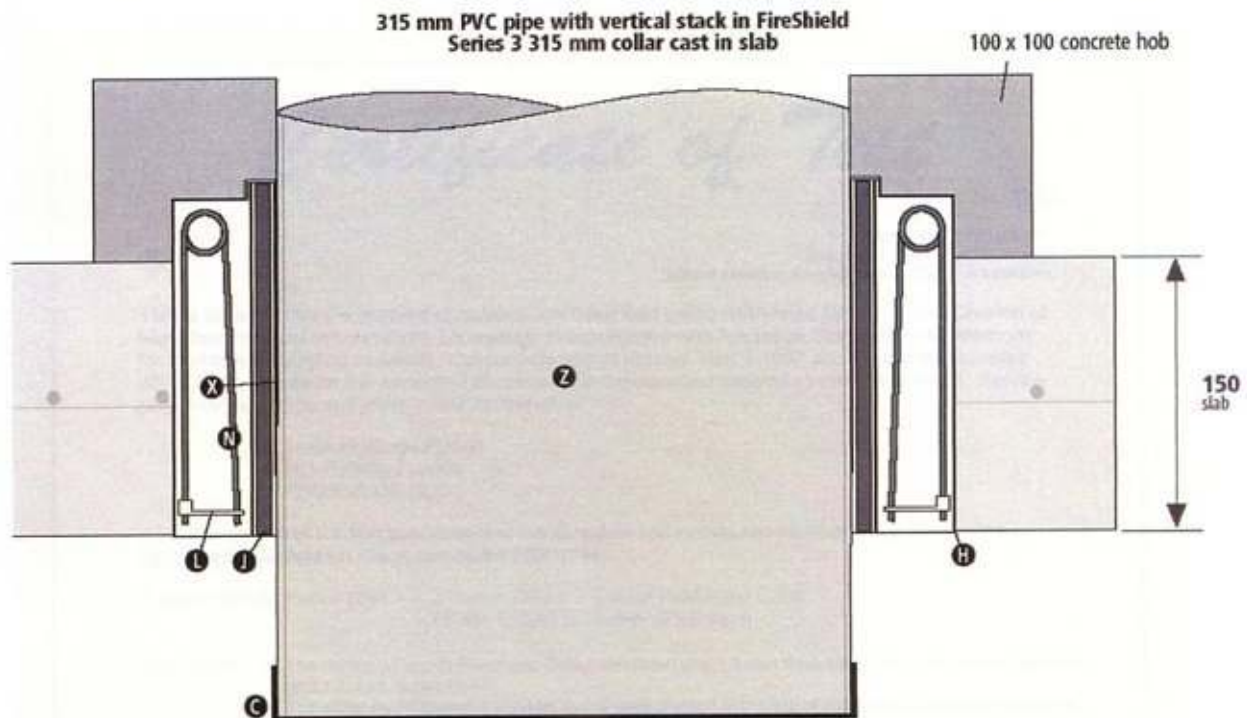

- A Rondo furring channels
- B Angled metal bracket (2 mm thick)
- C End cap
- D FireShield retrofit collar (1 mm thick metal)
- E FireShield cast-in collar (Polypropylene)
- F Floor flange
- G Intumescent and glass sleeve
- H FireShield cast-in collar (metal)
- I Intumescent
- J Intumescent and stainless steel sleeve
- K 3 sheets of 16 mm Fyrchek® plasterboard
- L Fusible link
- M Cement mortar
- N Spring for closing fire collar
- O Ceiling frame at 600 mm centres
- P Metal plate (1 mm thick)
- R Floor grate
- S Fire-rated sealant
- T Steel angles fixed to surface of sheeting
- U Stainless steel knock-in (5 x 40 mm long)
- V Screw into wall frame (5 x 40 mm long)
- W Screw into steel angles or Rondo furring channels (5 x 20 mm long)
- X Fibreglass liner
- Z 315 mm PVC pipe

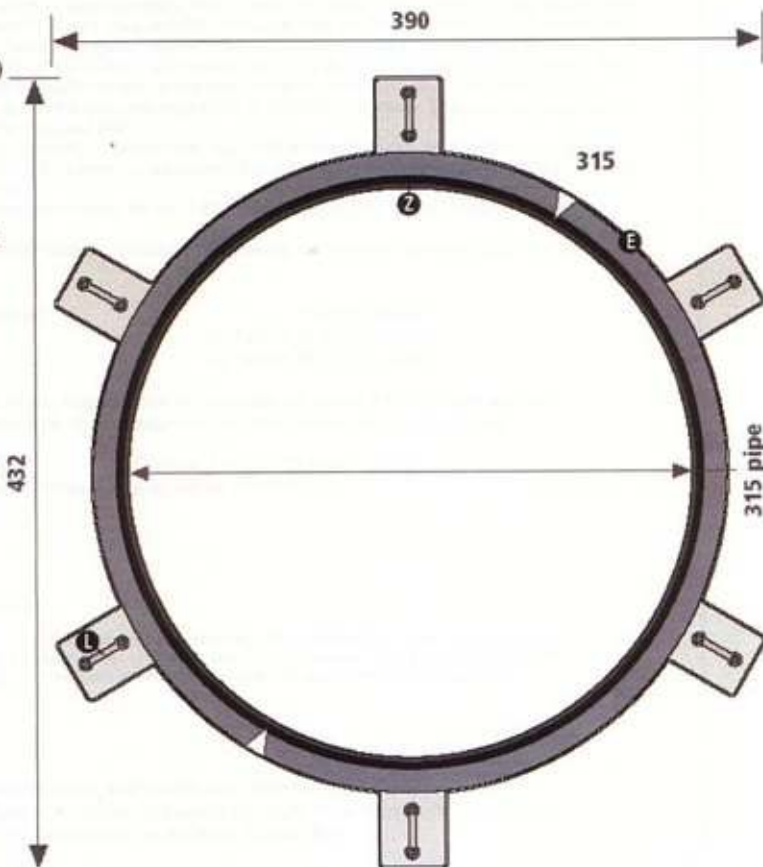

Drawing No.	FSTD73A010405
File	FSTD73A
Part No.	FS35315A
Pat. Pending	
Copyright by Fireball International Pty Ltd. All rights reserved. No part of this work covered by the copyright herein may be reproduced or used in any form or by any means - graphic, electronic or mechanical, including photography, recording, taping, or information storage and retrieval systems - without written permission of the publisher.	
All dimensions in mm.	



MANUFACTURING & INFRASTRUCTURE TECHNOLOGY

"Copyright CSIRO 2005 ©" Copying or alteration of this report without written authorisation from CSIRO is forbidden.



This laboratory is accredited (Accreditation No. 3632) by the National Association of Testing Authorities, Australia. The tests reported herein have been performed in accordance with its terms of accreditation.

Certificate of Test

No. 1923

© Copyright CSIRO 2005
Copying or alteration of this report
without written authorisation from CSIRO is forbidden.

This is to certify that the element of construction described below was tested by the CSIRO Division of Manufacturing and Infrastructure Technology in accordance with Australian Standard 1530, Methods for fire tests on building materials, components and structures, Part 4-1997 and Australian Standard 4072, Components for the protection of openings in fire-resistant separating elements, Part 1: Service penetrations and control joints -1992, on behalf of

Truss Holdings Pty Ltd
161 Railway Parade
THORNSIDE QLD

A full description of the test specimen and the complete test results are detailed in the Division's sponsored investigation report numbered FSP 1144.

Product Name: Penetration – 315-mm Series 3 Cast-in FireShield Collar
FS3S - 315A1 (315-mm uPVC pipe)

Description: The Series 3 Cast-in FireShield Collar consisted of a 1.2-mm thick steel case, 355-mm in diameter and 190-mm in height. The collar incorporated 6 springs, these were pivoted at the top of the spring cavity and restrained by a nylon fusible link with a melting temperature of 75 degrees Celsius. A soft intumescent wrap lined the internal circumference of the collar. The wrap was 10-mm thick x 180-mm wide, and weighed approximately 2860 grams. The wrap was covered on the outside with a stainless steel mesh 0.35-mm thick and 180-mm wide, and on the inside with a 0.35-mm thick x 57-mm wide Colan Type E fibreglass sleeve, extending down from the top of the collar 150-mm. A nominal 315-mm OD uPVC Vinidex stormwater pipe was fitted through the collar's sleeve. The pipe projected vertically 2000-mm above the slab and approximately 150-mm into the furnace chamber. The pipe above the slab was supported at 1000-mm intervals. The pipe was open at the top and capped at the exposed end. A concrete hob, approximately 100-mm high, was cast around the portion of the collar projecting above the slab, in order to maintain a minimum 50-mm concrete cover around all of the projecting steel case of the collar. Construction is detailed in drawing file No. FSTD73A, undated, by Fireball Collars Pty Ltd.

The element of construction described above satisfied the following criteria for fire-resistance for the period stated.

Structural Adequacy	-	not applicable
Integrity	-	no failure at 185 minutes
Insulation	-	no failure at 185 minutes

and therefore for the purpose of Building Regulations in Australia, achieved a fire-resistance level (FRL) of -/180/180. The FRL is applicable for exposure to fire from the same side as tested.

Testing Officer: Chris Wojcik Date of Test: 23 March 2005
Issued on the 15th day of August 2005 without alterations or additions.

Garry E Collins
Garry E Collins
Manager, Fire Testing and Assessments



This laboratory is accredited (Accreditation No. 3632) by the National Association of Testing Authorities, Australia. The tests reported herein have been performed in accordance with its terms of accreditation.



CSIRO Manufacturing & Infrastructure Technology
14 Julius Avenue, Riverside Corporate Park, North Ryde NSW 2113 AUSTRALIA
Telephone: 61 2 9490 5444 Facsimile: 61 2 9490 5555



MANUFACTURING & INFRASTRUCTURE TECHNOLOGY

© Copyright CSIRO 2005 Copying or alteration of this report without written authorisation from CSIRO is forbidden.



This laboratory is accredited (Accreditation No. 3632) by the National Association of Testing Authorities, Australia. The tests reported herein have been performed in accordance with its terms of accreditation.

Certificate of Test

No. 1923

"Copyright CSIRO 2005 ©"
Copying or alteration of this report
without written authorisation from CSIRO is forbidden.

This is to certify that the element of construction described below was tested by the CSIRO Division of Manufacturing and Infrastructure Technology in accordance with Australian Standard 1530, Methods for fire tests on building materials, components and structures, Part 4-1997 and Australian Standard 4072, Components for the protection of openings in fire-resistant separating elements, Part 1: Service penetrations and control joints -1992, on behalf of

Truss Holdings Pty Ltd
161 Railway Parade
THORNSIDE QLD

A full description of the test specimen and the complete test results are detailed in the Division's sponsored investigation report numbered FSP 1144.

Product Name: Penetration – 315-mm Series 3 Cast-in FireShield Collar
FS3S - 315A1 (315-mm uPVC pipe)

Description: The Series 3 Cast-in FireShield Collar consisted of a 1.2-mm thick steel case, 355-mm in diameter and 190-mm in height. The collar incorporated 6 springs, these were pivoted at the top of the spring cavity and restrained by a nylon fusible link with a melting temperature of 75 degrees Celsius. A soft intumescent wrap lined the internal circumference of the collar. The wrap was 10-mm thick x 180-mm wide, and weighed approximately 2860 grams. The wrap was covered on the outside with a stainless steel mesh 0.35-mm thick and 180-mm wide, and on the inside with a 0.35-mm thick x 57-mm wide Colan Type E fibreglass sleeve, extending down from the top of the collar 150-mm. A nominal 315-mm OD uPVC Vinidex stormwater pipe was fitted through the collar's sleeve. The pipe projected vertically 2000-mm above the slab and approximately 150-mm into the furnace chamber. The pipe above the slab was supported at 1000-mm intervals. The pipe was open at the top and capped at the exposed end. A concrete hob, approximately 100-mm high, was cast around the portion of the collar projecting above the slab, in order to maintain a minimum 50-mm concrete cover around all of the projecting steel case of the collar. Construction is detailed in drawing file No. FSTD73A, undated, by Fireball Collars Pty Ltd.

The element of construction described above satisfied the following criteria for fire-resistance for the period stated.

Structural Adequacy	-	not applicable
Integrity	-	no failure at 185 minutes
Insulation	-	no failure at 185 minutes

and therefore for the purpose of Building Regulations in Australia, achieved a fire-resistance level (FRL) of -/180/180. The FRL is applicable for exposure to fire from the same side as tested.

Testing Officer: Chris Wojcik Date of Test: 23 March 2005
Issued on the 15th day of August 2005 without alterations or additions.

Garry E Collins
Manager, Fire Testing and Assessments



This laboratory is accredited (Accreditation No. 3632) by the National Association of Testing Authorities, Australia. The tests reported herein have been performed in accordance with its terms of accreditation.



CSIRO Manufacturing & Infrastructure Technology

14 Julius Avenue, Riverside Corporate Park, North Ryde NSW 2113 AUSTRALIA
Telephone: 61 2 9490 5444 Facsimile: 61 2 9490 5555